

FREEWAY SA-160 Stand Aid



PRISM MEDICAL UK

Moving, Handling and Bathing Solutions™

FREEWAY SA-160 Stand Aid

The new Freeway SA-160 has an impressive range of features to provide a safe and dignified lift. Compact and easy to manoeuvre, the SA-160 is uniquely designed to provide 3 functions:-

- As a transfer hoist
- As a sit to stand hoist
- As an aid to rehabilitation by assisted standing

The SA-160 has a safe working load (SWL) of 160kg (25 stone)

PRISM Slings

Slings are the most important component of any hoist system as they are the interface between the client and the hoist.

Prism offer a comprehensive range in a variety of designs and materials.

A customisation service is offered to provide a unique client specific sling solution.

All Prism slings have colour coded bindings to indicate the sling size and unique colour coded loops to ensure the sling is correctly positioned and connected to the hoist.

PRISM SLING SIZE GUIDE	XX LARGE
	X LARGE
	LARGE
	MEDIUM
	SMALL
	JUNIOR
	CHILD

Sling Size Guide

Is provided for reference on the mast of the stand aid.

The Prism sling range includes specific slings for use in conjunction with Stand aids. Shown below are the Standing Support and Posterior slings.



Manual emergency lowering facility

Is provided for use in the unlikely event of a power or control box failure.



Control box

Displays battery information and charging status.

Emergency lowering button

Includes feature to allow the client to be lowered in the unlikely event of failure of the handset.

Emergency stop button



Situated on control box.

Push in to operate and rotate clockwise to reset.



Multi-directional knee pad

Allows for individual adjustment to provide full support.

On board charging

There is also the option of 'off board' charging of the battery pack which offers added flexibility.





Freecote®

The SA-160 has a durable protective coating which is easy to clean and includes 'Freecote' – our unique antimicrobial and antibacterial coating.

Freecote® is resistant against the hospital super bug MRSA, e-coli, salmonella and listeria



Actu-log

Included as standard – it records and displays the stand aid usage. It has the potential to increase the actuator lifespan.



Ergonomically designed handset

Simple 4 button operation of the hoist. Diagrams on the handset further enhance ease of operation.



Ergonomically profiled push handles

Allows for the safe moving and positioning of the stand aid.



Removable two position footplate

Allows for gait training and ease of cleaning.



Dual-wheeled castors

Makes the stand aid easy to manoeuvre on all surfaces.

Complete with rubber protectors on the front castors. The rear castors are lockable.



Rear Foot bar

Helps to negotiate the stand aid over uneven floor surfaces and door thresholds.



Powered leg opening (as standard)

Offers smooth, controlled leg opening to the desired position for a stable and safer lift without restricting access around chairs and beds.

Technical Specifications FREEWAY SA-160 PRISM MEDICAL UK

Model Specification	SA-160
Maximum Weight Capacity	160kg
Lifting Range	650 – 1,645mm
Stand Aid Foot Print (LxW)	1,100 x 640mm
Turning Radius	1,200mm
Legs Open – External Width	1,120mm
Legs Open – Internal Width	1,020mm
Legs Closed – External Width	720mm
Legs Closed – Internal Width	620mm
Overall Height of Legs (Top of Legs to Floor)	123mm
Ground Clearance (Underside of Leg to Floor)	50mm
Front Twin Castors (Diameter)	100mm
Rear Twin Castors (Diameter)	100mm
Weights	SA-160
Assembled SA-160	47.6kg
Mast & Boom (including all fittings)	23.7kg
Base Assembly	23.9kg

(Dimensions in mm and weights in kg)

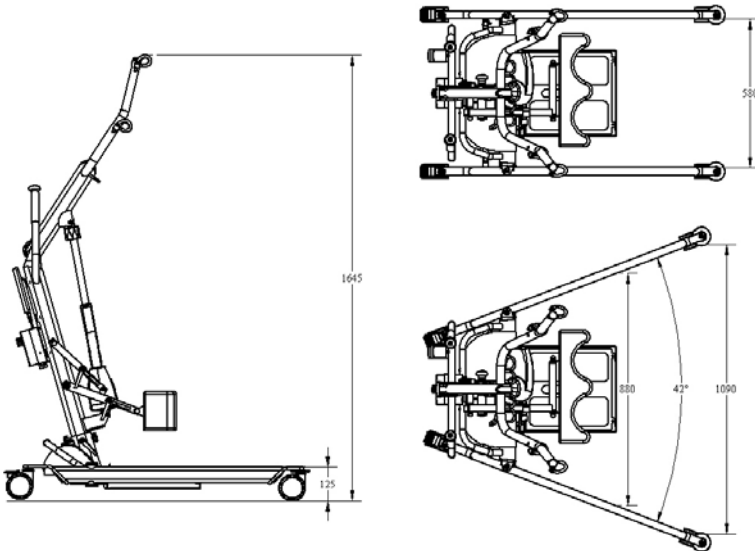

FULL 2 YEAR WARRANTY

(excludes batteries)

Made in the UK. The SA-160 Stand Aid meets and exceeds all relevant design, safety and quality standards

- ✓ BS EN ISO 10535:2006 Compliant 'Hoists for the transfer of disabled persons – Requirements and test methods'

Community Care

Prism Medical UK – Westholme Division (Northern Region)

Unit 4 Jubilee Business Park,
Jubilee Way, Grange Moor, Wakefield,
West Yorkshire WF4 4TD UK
Tel: +44 (0) 844 980 2260
Fax: +44 (0) 844 980 2261
E-mail: info@westholme.co.uk
www.prismmedical.co.uk

Prism Medical UK – Westholme Division (Southern Region)

Unit 7, Saracen Industrial Estate,
Mark Road, Hemel Hempstead,
Hertfordshire HP2 7BJ UK
Tel: +44 (0) 844 980 2263
Fax: +44 (0) 844 980 2264
E-mail: info@westholme.co.uk
www.prismmedical.co.uk

Prism Medical UK – Liftech Division & Test Valley Division

Unit 42 South Hampshire Industrial Park, Totton,
Southampton, Hampshire SO40 3SA UK
www.prismmedical.co.uk

Liftech Division

Tel: +44 (0) 844 980 2272
Fax: +44 (0) 844 980 2273
E-mail: sales@liftechsystems.co.uk

Test Valley Division

Tel: +44 (0) 844 980 2269
Fax: +44 (0) 844 980 2270
E-mail: admin@testvalleymobility.co.uk

Prism Medical UK – Carefree Division

13 - 15 Pennington Street, Hindley,
Wigan, Lancashire WN2 3AH UK
Tel: +44 (0) 844 980 2266
Fax: +44 (0) 844 980 2267
E-mail: info@carefreelifting.co.uk
www.prismmedical.co.uk

Prism Medical UK - Movement2 Division

Unit 8 The Warren,
East Goscote Industrial Estate,
East Goscote, Leicestershire LE7 3XA
Tel: +44 (0) 844 980 2281
Fax: +44 (0) 844 980 2282
E-mail: mail@movement2.co.uk
www.movement2.co.uk

Long Term Care

Prism Medical UK – Long Term Care

Unit 4 Jubilee Business Park,
Jubilee Way, Grange Moor, Wakefield,
West Yorkshire WF4 4TD UK
Tel: +44 (0) 844 980 2260
Fax: +44 (0) 844 980 2261
E-mail: careinfo@westholme.co.uk
www.prismmedical.co.uk

Prism Medical UK – Saluss Division

Unit 1, Tir Llwyd Industrial Estate, St Asaph Avenue,
Kinmel Bay, Rhyl, Conwy LL18 5JZ UK
Tel: +44 (0) 844 980 2290
Fax: +44 (0) 844 980 2291
E-mail: helpdesk@saluss.co.uk
www.prismmedical.co.uk

Acute Hospital Care

Prism Medical UK – Healthcare Division

Unit 4, Crispin Court, Newbiggin Lane, Newcastle Upon
Tyne, Tyne & Wear NE5 1BF UK
Tel: +44 (0) 844 980 2278
Fax: +44 (0) 844 980 2279
E-mail: healthcareinfo@prismmedical.co.uk
www.prismmedical.co.uk

Prism Medical UK – APLS Division

Unit 4, Crispin Court, Newbiggin Lane,
Newcastle Upon Tyne, Tyne & Wear NE5 1BF UK
Tel: +44 (0) 844 980 2275
Fax: +44 (0) 844 980 2276
E-mail: info@assured-pls.com
www.prismmedical.co.uk

